



X-RAY ILLUMINATORS

**Technical
Publication**

MAMMO ILLUMINATOR

Operating Documentation

**Installation
Operation
Maintenance**

**Document #TP1010
Copyright 2005 Maxant Technologies, Inc.
All rights reserved**

REV 10/27/2005

CAUTION!! Do not attempt any maintenance on this equipment unless the unit is disconnected from the power source.



MEDICAL EQUIPMENT WITH RESPECT TO ELECTRIC SHOCK FIRE AND MECHANICAL HAZARDS ONLY IN ACCORDANCE WITH UL60601-1, AND CAN/CSA C22.2 NO. 601.



Attention, Consult Accompanying Documents.

TYPE OF PROTECTION AGAINST ELECTRICAL SHOCK: CLASS I



ENVIRONMENT:

Ambient temperature range of +10°C to 40°C

Relative humidity range of 30% to 75%

Atmospheric pressure range of 700 hPa to 1 060 hPa

Read Immediately:

All packages must be closely inspected for damage upon receipt. Compare the quantity listed on the packing slip with the bill of lading. **Any damage or shortage to the shipment must be noted on the bill of lading at the time of delivery.**

Once a bill of lading is signed for, the likelihood of collecting any amount on a concealed freight claim is significantly reduced.

All damages, noted or concealed, must be reported to the carrier within 15 days of the delivery date. Transportation companies will not honor a claim if the request for inspection is not made within this 15-day period. **MAXANT cannot be held responsible for damage noted after delivery.**

Thank you!

Dear Valued MAXANT Customer:

Thank you for your purchase of MAXANT illuminators. MAXANT takes pride in ensuring that you and your facility enjoy many years of quality illuminator performance. We very much appreciate your business and look forward to the opportunity to serve you again.

If you have any questions or comments, please contact your local MAXANT dealer or call us directly at 800-307-4190.

MAXANT Technologies, Inc.
7540 Caldwell Avenue, Niles, IL 60714
800-307-4190, 847-588-2280, Fax 847-588-1920
www.maxant.com customerservice@maxant.com

Table of Contents

1.0	Introduction	Page 5
2.0	MAMMO Features	Page 5
3.0	Product Specifications – Electrical and Illumination	Page 5
3.1	Ballast	Page 6
3.2	Lamps	Page 6
3.3	Line Cord	Page 6
3.4	Radiated and Conducted Emissions	Page 6
3.5	Fuses	Page 6
3.6	Light Output	Page 7
4.0	Product Specifications, Mechanical	
4.1	Body Construction	Page 7
4.2	Diffusion Panel	Page 7
4.3	Film Grip	Page 7
5.0	Dimensional and Shipping Weight Information	Page 8
6.0	Surface Mounting Instructions	
6.1	Surface Mounting Installation Diagrams	Page 9
6.2	Recommended Wall Structure Build Diagram For UL60601-1 Installation	Page 12
7.0	Operation of the TECHLINE Illuminators	
7.1	Standard Switching	Page 13
7.2	Master Switch	Page 13
8.0	Internal Access and Maintenance	
8.1	Replacing Lamps	Page 14
8.2	Replacing the Ballast	Page 14
8.3	Replacing Fuses	Page 15
8.4	General Maintenance	Page 15
9.0	Trouble Shooting Guide	Page 16
10.0	Replacement Parts Lists	
10.1	Exploded Drawings	Page 17
10.2	Part List	Page 19

1.0 Introduction

This manual covers dimensional information, operational instructions and technical specifications for the MAMMO series illuminators. These devices are intended to aid in the reading of medical x-ray films using back lighting. All MAMMO illuminators are shipped with lamps ready to install and operate. Remove the shipping tape from the lamp sockets before operating.

2.0 Standard and Optional MAMMO Features

Standard features include:

- Roller Gravity Film Grip
- Easy maintenance and easy lamp replacement

Additional optional features (all are standard on UL60601-1 certified fixtures) for the TECHLINE as a Class One continuous operation medical device:

- Certification to UL60601-1 (EN60601-1) and CE
- Double Pole Master Switch
- Hospital grade plug
- Dual fusing
- Additional filtering for conducted emissions on multi-panel units
- Meets NFPA 99

3.0 Product Specifications – Electrical and Illumination

WARNING: USE ONLY SPECIFIED FUSE SIZES AND TYPE

Series	Voltage	Current	Power	Leakage	NITS/Unit	Power	No. Of	Fuse
TS & TR	60 Hz	Amps	Watts	Micro-amps	CD/M*M	Factor	Panels	Amps
MAM301	117.5	0.9	90	29	3300	0.922	1	2
MAM311	117.5	1.8	180	58.00	3300	0.922	2	2
MAM303	117.5	0.90	90.	29	3300	0.922	1	2
MAM313	117.5	1.8	180	58.0	3300	0.922	2	2

Series	Voltage	Current	Power	Leakage	NITS/Unit	Power	No. Of	Fuse
TS & TR	50 Hz	Amps	Watts	Micro-amps	CD/M*M	Factor	Panels	Amps
MAM301	230	0.45	90	29	3300	0.922	1	1
MAM311	230	0.9	180	58.00	3300	0.922	2	1
MAM303	230	0.45	90	29	3300	0.922	1	1
MAM313	230	0.9	180	58	3300	0.922	2	1

This measured data is considered typical and nominal. Data may vary from unit to unit.

3.1 Ballast

Electronic, Class P, Type 1, Low Leakage.

3.2 Lamps

Type F30T12/D daylight type fluorescent lamp

3.3 Line Cord

Grounded chassis with 8-foot, 3-wire line cord
NEMA 5-15P, 2-pole, 3-wire ground
Hospital grade cord and plug for UL60601-1 units

3.4 Radiated or Conducted Emissions

This equipment has been tested and found to comply with the limits of a Class B digital device, pursuant to Part 15 of the FCC rule. It has also been tested and found to comply with CISPR 15 for Class One medical devices. These limits are designed to provide reasonable protection against harmful interference to other electronic equipment and radio communications. However, there is no guarantee that interference will not occur in a particular installation. If this equipment does cause harmful interference to other electrical equipment or radio/television reception, try one of the following corrective measures:

- Relocate the electronic equipment or its receiving antenna.
- Increase the distance between the illuminator(s) and the electronic equipment that is exhibiting interference.
- Connect the illuminator(s) to an outlet on a different circuit than the interfered electronic equipment.
- Consult the dealer or an experienced radio technician for help.

3.5 Fuses (UL or EN 60601-1 only)

Use only fuse IEC Fast-acting type 5x20mm ceramic. See tables for correct fuse size. **FUSE MUST BE UL, SEMCO, BSI, VDE, CSA, AND MITI LISTED.** Please place the order with your Maxant distributor. The "Littlefuse Co." type 216 series is a qualified fuse.

3.6 Light Output

These light levels are taken from procedures specified by the German DIN6865 standard. Currently this is the only published standard for evaluating the luminance levels of x-ray illuminators. These levels were measured under the following conditions: an ambient temperature of 21° Celsius (70° Fahrenheit), 118 Volt line voltage, and new lamps that were allowed to be on for 2 hours before the measurements were made. Light levels measured in the field may vary with the local environment, including: lamp age, line voltage, ambient temperature, and lamp temperature. The measurements published here are subject to change without notice.

4.0 Product Specifications - Mechanical

4.1 Body Construction

- 18-gauge welded steel construction
- Multi-panel configurations manufactured as an integral assembly

4.2 Diffusing Panel

- Easily removed to replace lamps – no tools required
- Shatter resistant, UL recognized MC thermoplastic

4.3 Film Grip

- Self-adjusting roller-gravity film grip accommodates every film thickness.
- Will not scratch or tear film
- Open sides facilitate viewing of oversized films
- Bottom film ledge accommodates small film formats

5.0 Dimensional and Shipping Weight Information

SURFACE MOUNT

Number Of Panels	Viewing Area Inches	Fixture Length Inches	Fixture Height Inches	Weight Lbs.
MAM301	11x36	36	13	17.5
MAM311 -1 Over 1	2x11x36	36	26	33
MAM303	14x17	47	15	25
MAM313 – 1 over 1	2x14x17	47	30	50

6.0 Installation and Mounting Instructions

6.1 Surface Mounting Installation Diagram

Cut sheets for all models are available on our web site www.maxant.com or Contact us directly.

SERIES: MAMMO
 MODEL NUMBER: MAM301
 DESCRIPTION: SINGLE PANEL, 3 LAMP, SURFACE MOUNT CONFIGURATION

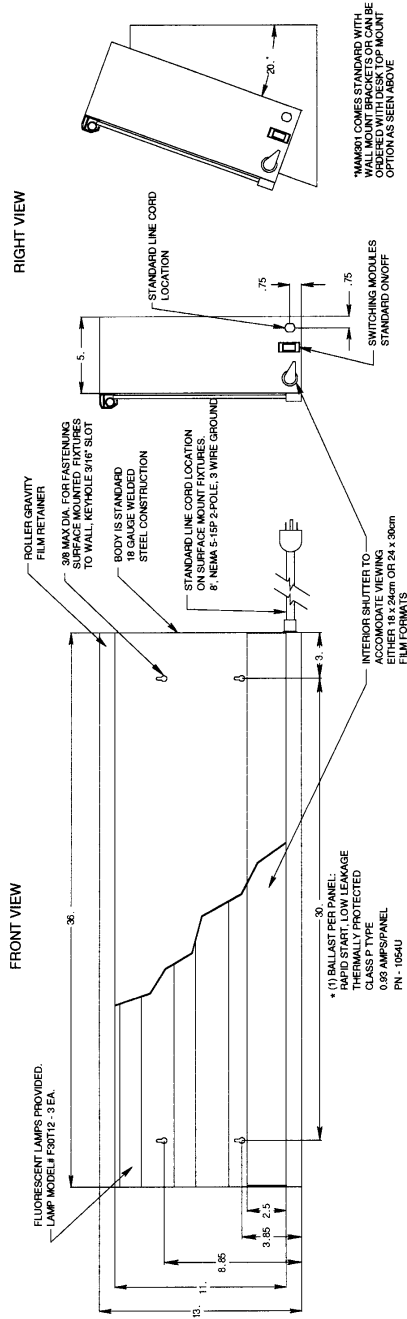

MAXANT TECHNOLOGIES, INC.
 7540 CALDWELL AVE.
 NILES, IL 60714
 (847) 381-4198

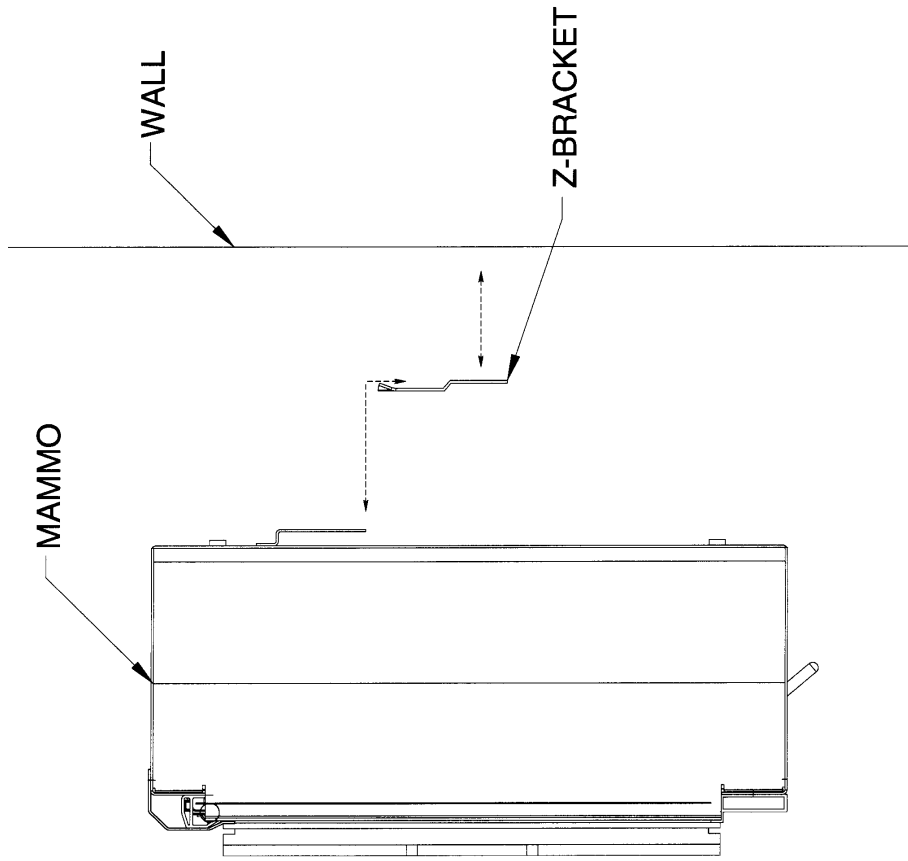

- Mount z-bracket to wall,
- slide mammo over z-bracket

6.2 Suggested Wall Structure Build Diagram for UL60601-1 Installation.

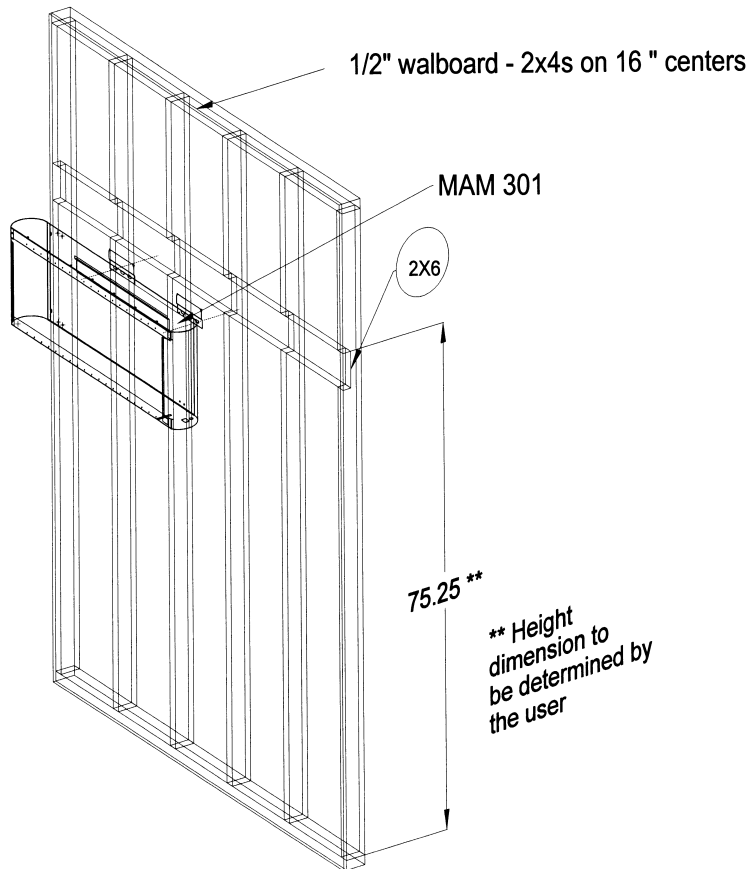

The wall shown is a standard wood frame wall made from 2x4's covered with 1/2" plaster wallboard. The cross pieces needed for mounting the illuminators are one 2x4 and two 2x6's. The vertical studs are notched to accept the cross pieces as shown in the diagram. Use #10 x 2 1/2" deckboard countersunk head stainless steel screws to secure the cross pieces to the 2x4 wall. Use two screws per stud for the 2x6's and one screw per stud on the 2x4.

Attach illuminators to the wall using #8 x 1 1/2" round or Phillips head wood screws and 3/4" OD #8 fender washers. For single-tier units, use four screws per unit. For double-tier units, use two screws per unit on the upper tier and four screws per unit on the lower tier. As an alternate, use #8 high performance serrated thread screws for power drivers (a.k.a. SPAX and ABC types).

7.0 Operation of the TECHLINE Illuminators

7.1 Standard Switching

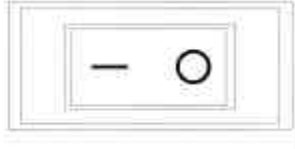

Standard switching provides a two-position “ON/OFF” rocker switch per panel. UL187/CSA114 products use a single pole/single throw switch.

7.2 Master Switch

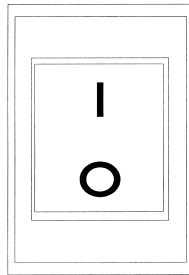

The master switch option provides a two-position “ON/OFF” rocker switch that controls the power to the entire fixture. A master switch is required for UL60601-1 certified fixtures when hard wired. The master switch has two poles and disconnects both sides of the line from the main.

8.0 Internal Access and Maintenance

The unique design of the MAMO illuminator series allows for easy internal access for lamp replacement, ballast replacement and fixture maintenance.

WARNING – ALWAYS DISCONNECT THE POWER TO THE FIXTURE BEFORE ATTEMPTING TO ACCESS THE UNIT INTERNALLY. DO NOT TOUCH THE LAMP SOCKET AND THE PATIENT AT THE SAME TIME.

8.1 Replacing Lamps

Carefully observe the Plexiglas diffusing panel. Note that the panel rests in the back groove of the bottom film ledge and its top fits into the film grip. To remove this panel, grasp the panel near the bottom on both sides and lift it up until it is above the lower film ledge. Then pull out the bottom of the Plexiglas until it clears the film ledge and move it down until it is clear of the film grip on top. **TO AVOID SCRATCHING THE PLEXIGLAS OR DAMAGING THE FILM SWITCH, AVOID SLIDING THE PLEXIGLAS OUT SIDEWAYS.** Carefully set the Plexiglas on one end and lean it against the wall.

Be sure to remove any extra shipping tape. The lamps are removed by simply pulling them towards you without any rotation. Replace the lamp by firmly pushing it forward until the lamp is seated in the socket. It is a good idea to replace all lamps even if only one has burned out to insure even illumination.

To replace the Plexiglas diffusing panel, align it with the sides of the housing and slide it up into the film grip. Then push the bottom of the Plexiglas into the film grip until it fits comfortably.

8.2 Replacing the Ballast

Disconnect your illuminator(s) from power. First, remove both the Plexiglas diffusing panel (as described in 8.1.) Remove the two screws found inside of the lamp housing to free the wire-way cover and remove the cover. Next, remove the hex nut securing the ballast to the fixture. Check your replacement ballast. It should have the same color wires as the ballast that is in the fixture. If it does not, you may have the wrong ballast. If the wire colors match,

cut the wires connecting the defective ballast to the illuminator, leave as much length as possible. Remove the defective ballast.

Insert the new ballast into position and secure it with the hex nut. Strip the wires you have cut. Attach each stripped wire to its corresponding color entrance on the new ballast. Tug on the connectors. The wires should stay firmly attached. Replace the wire-way cover and Plexiglas panel as described in 8.1. Connect the unit back to power turn it on.

8.3 Replacing Fuses (UL/EN 60601-1 only)

Disconnect the unit from the power source. Remove the Plexiglas defusing panel. Remove the two screws that hold the wire-way cover that contains the master switch (Usually the right most panel). Observe the two fuses mounted side by side. Test the fuses for conductivity and remove the fuse that is defective. **Replace the fuse with the specified size and type.** Replace the wire-way cover and the two screws. Replace the Plexiglas panel as describer in 8.1. Connect the unit back to power and turn it on. **IF THE FUSE BLOWS AGAIN, STOP AND DETERMINE WHAT THE CAUSE MAY BE BEFORE INSERTING ANOTHER FUSE.**

8.4 General Maintenance

Routine maintenance on all illuminators is necessary for clean, unobstructed viewing equipment. The illuminator's interior and exterior surfaces and diffusing panels should be periodically wiped down with a soft cloth and a mild cleansing agent. **Do not use ammonia or abrasive cleaners because they will scratch and fade surfaces.** In the event the painted surfaces become scratched, please contact your local MAXANT dealer for touch-up paint.

9.0 Trouble Shooting Guide

Note: Only trained and qualified personnel should gain access to the internal components to trouble shoot the equipment.

SYMPTOM	POSSIBLE CAUSE	CORRECTIVE ACTION
No light in the entire fixture.	Blown fuse or open circuit breaker at the fuse box. CAUTION – THIS MAY BE AN INDICATION OF EITHER CIRCUIT OVERLOAD OR THAT A PROBLEM EXISTS ON THE CIRCUIT	Replace fuse or reset circuit breaker. Check for 117V 60 Hz at receptacle.
	Faulty power cord or plug	Gain access to the ballast compartment and verify connections between the line cord and the fixture. Check power cord or plug. If defective, replace or repair.
One panel will not light up.	All fluorescent lamps are burned out or broken	Replace fluorescent lamps.
	Faulty power switch for that panel	Check for 117 V at output side of the “ON/OFF” or “ON/OFF/AUTO” switch when in the “ON” position. If there is no voltage, replace the switch.
	Defective Ballast	Check for voltage (117V) on the ballast. If voltage is present and the lights still do not light, replace the ballast. If voltage is not found, repeat troubleshooting steps above.
Some of the lamps in one section fail to light. Some or all sections are slow to start or the lamps flicker when the fixture is on.	Lamp burned out or loose connection between the ballast and the lamp holder	Replace burned out lamps. Replace all lamps at the same time in order to maintain even illumination. Check connections to lamp holders.
	Poor or missing ground connection	Determine that a proper ground is coming into the fixture as well as the power receptacle. Verify that the ground prong on the plug is connected in the outlet.
	Air temperature in the room is below 50°F or air temperature blowing on the fixture is below 50°F	Increase the air temperature. Move illuminator away from air vents.
Individual lamps are slow to start in one section of the fixture.	Lamp is old and malfunctioning	Replace all lamps to maintain even illumination. Verify connections to the lamp holders.
Some sections are darker than others in the fixture.	Mixture of old and new lamps	Replace all lamps to even out the illumination.
	Mixture of cool white and daylight type lamps	Use only daylight type lamps in illuminators.

10. Replacement Parts List and Drawing

10.1 Expanded Drawing Mammo 303

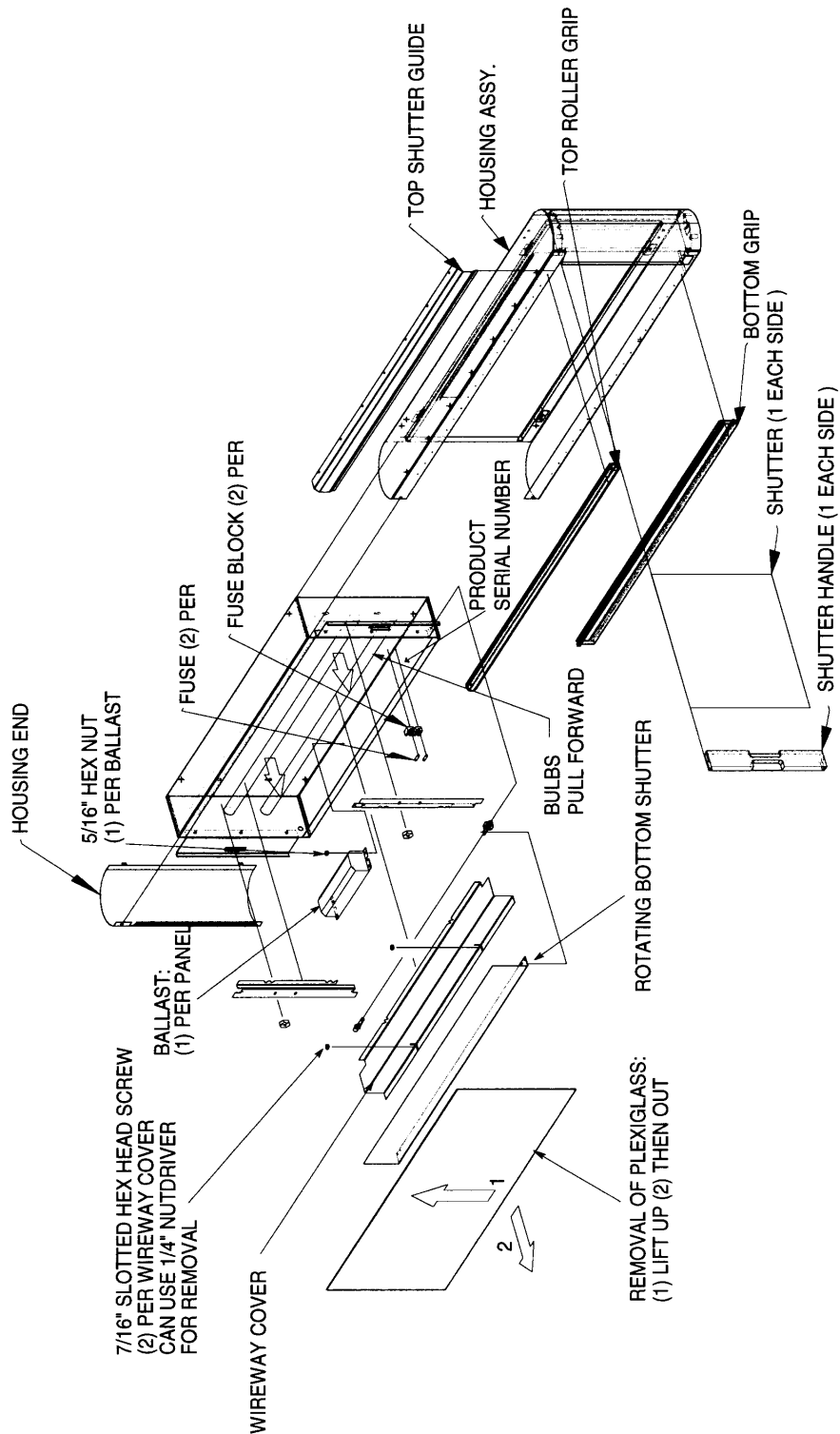

10.2 Expanded Drawing Mammo 303

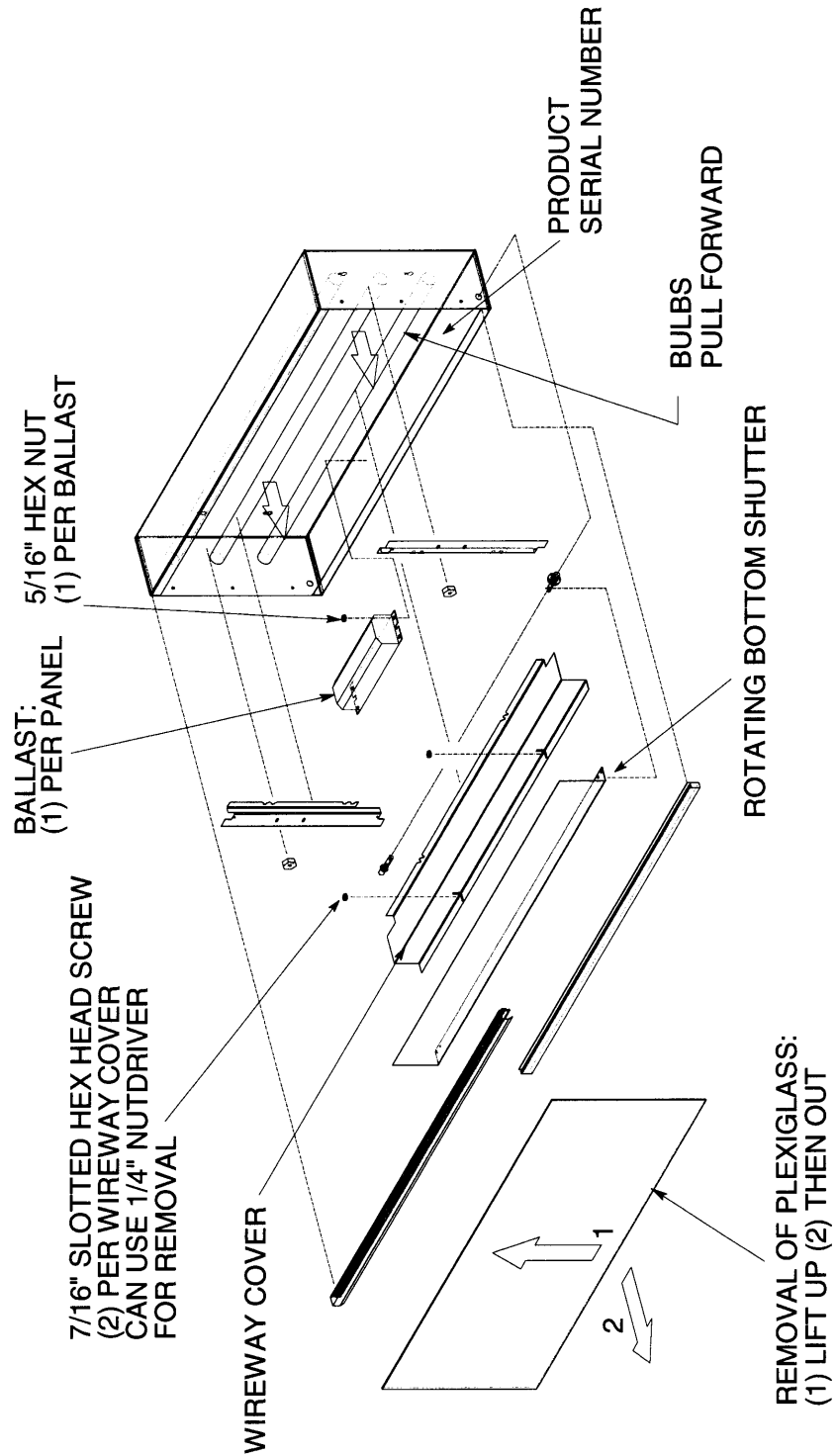

10.3 Parts List

Part Name	Part Description	Part Type	MAXANT Item No.
Master Switch	Two position "ON/OFF" rocker switch	One style per fixture	1117
"ON/OFF" two position rocker switch	Standard SPST "ON/OFF" rocker switch	One style per fixture	1122
Ballast 117V 60Hz	MAM301/311/303/313	Three Lamp	1054U
Ballast 230V 50 Hz	MAM301/311/303/313	Three Lamp	
Roller Gravity Grip	Film holding system	One per panel	1292
Bottom Extrusion	Bottom plexiglas holder	One per panel	1270A
Plexiglas	Diffusing Panel MAM301/311	1 Panel Section	1647
	Diffusing Panel MAM303/313	1 Panel Section	1648
Line cord assembly	Standard line cord	One style per fixture	1125
Line cord assembly	Hospital Grade (UL60601-1)	One style per fixture	1308
Lamp holders	Sockets for lamps	One style per fixture	1279A
Fuse	2 amp	Two per fixture	1012